

Chromate-Free Anti-Fingerprinting Electrogalvanized Steel Sheet

无铬耐指纹电镀锌钢板

www.baosteel.com



灵巧之钢，启迪生活的灵感

Exquisite Steel Inspires Life

Preface 前言

向社会提供安全、环保的产品，是宝钢的使命和应尽的社会责任。随着有关污染环境的化学物质禁止性法律法规和行业要求的相继出台，宝钢从产品设计、采购、制造、交付全过程致力于安全环保以及减轻环境负荷，陆续推出了安全环保的无铬耐指纹电镀锌系列产品。

本手册介绍的无铬耐指纹电镀锌产品符合下列法律法规要求：

欧盟RoHS指令《关于在电子电气设备中限制使用某些有害物质指令》(2002/95/EC)

欧盟WEEE指令《关于报废电气电子设备指令》(2002/96/EC)

注：RoHS和WEEE两指令于2003年1月27日同时发布，其中RoHS指令于2006年7月1日起实施，WEEE指令于2005年8月13日起实施。

欧盟PFOS指令《关于限制全氟辛烷磺酸销售及使用的指令》(2006/122/EC)

注：2006年12月27日发布和生效，该指令要求各成员国于2008年6月27日开始实施限制措施。

REACH指令《关于化学品注册、评估、许可和限制的法规》(第1907/2006(EC)法规)

注：欧盟于2006年12月立法通过，并于2007年6月1日起生效。

日本的《资源有效利用促进法实施令》(2006年7月1日实施)

中国的《电子信息产品污染防治管理办法》(信息产业部第39号令)

注：于2006年2月28日颁布，2007年3月1日起实施。



Baosteel are committed to supply of products of safety, environmental preservation and excellent quality. Baosteel take on the responsibility for reducing environmental impact through the total processes from product's quality design, purchasing, manufacturing to delivery. The serial products of Chromate-Free Anti-fingerprinting electrogalvanized steel sheet have been launched continuously.

The chromium-free anti-fingerprinting electro-galvanized steel products as presented herein conform to the laws and by-laws as follows:

Directive 2002/95/EC on the restriction on the use of certain hazardous substances in electrical and electronic equipment;

Directive 2002/96/EC on waste in electrical and electronic equipment (WEEE);

Notes: The RoHS and WEEE directives were both issued on Jan. 27, 2003, while RoHS Directive went into effect as of Jul.1, 2006 and WEEE Directive as of Aug.13, 2005.

Directive 2006/122/EC (PFOS) on the restriction on the marketing and use of certain dangerous substances and preparations (perfluorooctane sulfonates);

Notes: This directive was issued and went into effect as of Dec.27, 2006, and it is required all EU member states shall implement the restriction measures as of Jun.27, 2006.

Directive 1907/2006/EC (REACH) Concerning the Registration, Evaluation, Authorization and Restriction of Chemicals;

Notes: This regulation was a new EC legislation as of Dec. 2006 and went into effect as of Jun.1, 2007;

Japan's "Directive on Promoting the Effective Use of Resources" that went into effect as of Jul.1, 2006;

China's "Administrative Regulation on the prevention and treatment of the pollution of Electronic and Information Products" (the directive of the State Information Industry Ministry No. 39)

Notes: This regulation was issued as of Feb.28, 2006 and went into effect as of Mar.1, 2007.



Contents

目 录

产品特性	01
Product Characteristic	
可供牌号、规格和镀层重量范围	03
Symbol, Dimension & Coating Mass	
主要技术要求	03
Technical Requirements	
生产工艺	05
Production Process	
产品表面性能示例	06
Example of Typical Properties	
使用注意事项	09
Precaution in Use	
订货须知	10
Ordering Information	
包装、标志及检验文件	10
Packaging, Marking and Inspection Certificate	

■ 申明

本手册所述内容是对产品的代表性能和代表特征的介绍，除明确表示为“标准”的内容外，并不是对所述技术信息的保证承诺。

对于由于误用、不当使用本手册所述技术信息而造成的损失，由使用方自负，敬请谅解。

自本手册公布后，所述技术信息会有所变化，请向相关部门咨询最新信息。

■ Notice

The information contained in this publication is typical properties for products (excluding identified as "specified value".)

The use of the information is at the reader's risk and it is not warranted for the technical information included herein.

The information in this publication should be subject to modification without notice. Please contact concerned department for the newest information.

产品特性

Product Characteristic

SECC、SECD、SECE耐指纹系列产品特性

Characteristic for series of Chromate-Free Anti-fingerprinting electrogalvanized steel sheet

牌号 Symbol	表面涂层类型 Surface Treatment	代号 Code	耐指纹性 Fingerprint Resistance	耐蚀性 Corrosion Resistance	加工性 Workability	导电性 Conductibility	润滑性 Lubricity	涂装性 Painting Adhensiveness
SECC SECD SECE	普通型 General Use	N5	◎	○	○	○	△	◎
	优良导电型 Good Conductivity	NE	◎	○	○	◎	○	◎
	自润滑型 High Lubricating	SL	◎	◎	◎	△	◎	○
	高耐蚀型 High Corrosion Resistant	NC	◎	◎	○	-	-	-
	优良加工型 High Formability	NF	◎	-	◎	-	-	-
	优良涂装型 Good Painting Adhensiveness	NP	◎	-	-	-	-	◎

■ 可供
 ■ 研发中
 ■ 计划中

说明:

- ◎ 优秀
- 好
- △ 一般
- 相关试验目前尚未进行

耐溶剂性 Solvent Resistance	耐热性 Heat Resistance	耐酸性 Acid Resistance	耐碱性 Alkaline Resistance	
◎	○	◎	◎	液晶组模、DVD、机顶盒、音响、 电脑机壳、通讯机柜、导航仪等 Liquid crystal monolayer, enclosures for DVD, set top box, hi-fi set, and computer, communication equipment, navigational instruments etc.
◎	○	○	◎	复印机、传真机、打印机等OA行业 OA equipment (including duplicating machine, printer, etc.)
○	○	○	◎	微电机、风机外壳等深冲件 Deep drawing uses (including micro- motor, fan etc.
—	—	—	—	高耐蚀要求的家电产品零部件 Domestic appliance parts that require high corrosion resistance
—	—	—	—	高加工要求的家电产品零部件 Domestic appliance parts that require high workability
—	—	—	—	高涂装要求的家电产品零部件 Domestic parts that require high paint adhesiveness

■ 产品构成和功能

Composition and Function of Product

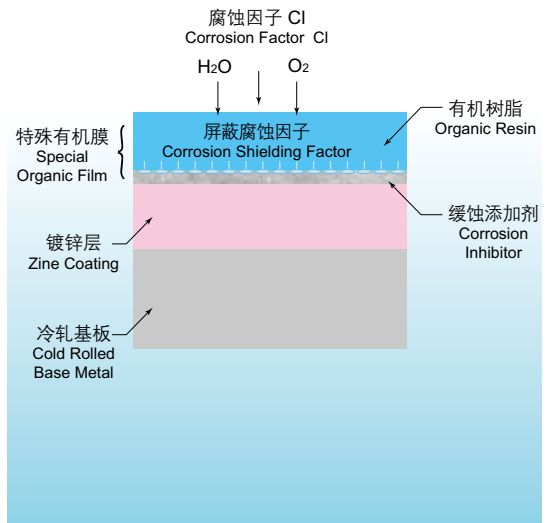

Available Under R&D In the works

Notes:

- ◎ Excellent
- Good
- △ Average
- The tests concerned are yet to be carried out.

可供牌号、规格和镀层重量范围 Symbol, Dimension & Coating Mass

可供牌号、规格和镀层重量范围

Symbol, Dimension & Coating Mass

种类 Type	牌号 Symbol	镀层重量(每面) Coating Mass (per side) g/m ²	规格范围 mm Dimension Range	
			厚度 Thickness	宽度 Width
一般用 For Common Use	SECC	10~40	0.4~2.0	800~1400
冲压用 For Drawing	SECD	10~40	0.4~2.0	800~1400
深冲用 For Deep Drawing	SECE	10~40	0.4~2.0	800~1400

对规格和镀层重量有特殊要求时，可协商供货
If there is any special requirement on dimension and coating mass excluding listed above, please contact us.

可供规格范围

Dimension Range

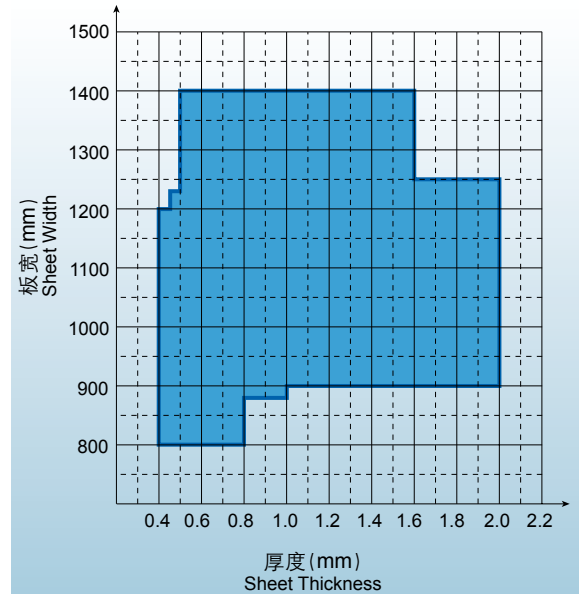

主要技术要求 Technical Requirements

镀层重量标准规定值

Specified Value for Coating Mass

推荐的锌层重量g/m ² Coating Mass as Recommended	最小单点值(每面) g/m ² Min. Value at One Point (per side)	最小三点平均值(每面) g/m ² Min. Value at Three Points (per side)
10/10	8.5	10
20/20	17	20
30/30	25.5	30
40/40	34	40

表面等级

Surface Quality

级别 Surface Quality Grade	代号 Symbol	特征 Characteristics
较高级 Normal	FB	不得有漏镀、镀层脱落、裂纹等缺陷，但不影响成型性及涂漆附着力的轻微缺陷，如小划痕、小辊印、轻微的刮伤及轻微氧化色等缺陷则允许存在。 Defects such as uncoated surface, flaking, crack are not permitted. Imperfections such as pimples, small marks, slight scratches, pits, variations in surface appearance, dark spots, stripe marks and light passivation stains which do not effect formability or the application of subsequent coatings are permissible.
高级 Improved	FC	产品二面中较好的一面必须对轻微划痕、辊印等缺陷进一步限制，另一面必须至少达到FB的要求。 The better of the two surface shall be much stricter on imperfections, such as slight scratches, roll marks, the other surface quality shall have at least the characteristics of surface quality FB.
超高级 Best	FD	产品二面中较好的一面必须对缺陷进一步限制，即不能影响涂漆后的外观质量，另一面必须至少达到FB的要求。 The better of the two surface shall be virtually free from surface imperfection liable to impair the uniform appearance of a high quality paint finish, for single coating, this requirements shall apply for the uncoated surface unless otherwise agreed. The other surface quality shall have at least the characteristics of surface quality FB.

■ 产品厚度允许偏差——标准规定值

Thickness Tolerance—Specified Value

公称厚度 Nominal Thickness	厚度允许偏差/Thickness Tolerance				
	普通精度/Normal (PT.A)			高级精度/Restricted (PT.B)	
	公称宽度 mm/Nominal Width			公称宽度 mm/Nominal Width	
	≤ 1200	> 1200~1500	> 1500	≤ 1200	> 1200~1400
≤ 0.40	± 0.03	± 0.04	± 0.05	± 0.020	± 0.025
> 0.40~0.60	± 0.03	± 0.04	± 0.05	± 0.025	± 0.030
> 0.60~0.80	± 0.04	± 0.05	± 0.06	± 0.030	± 0.035
> 0.80~1.00	± 0.05	± 0.06	± 0.07	± 0.035	± 0.040
> 1.00~1.20	± 0.06	± 0.07	± 0.08	± 0.040	± 0.050
> 1.20~1.60	± 0.08	± 0.09	± 0.10	± 0.050	± 0.060
> 1.60~2.00	± 0.10	± 0.11	± 0.12	± 0.060	± 0.070

■ 不平度标准规定值

Flatness—Specified Value

公称宽度 Nominal Width	不平度 不大于/Flatness not greater than					
	普通精度/Normal (PF.A)			高级精度/Restricted (PF.B)		
	公称厚度 mm/Nominal Thickness			公称厚度 mm/Nominal Thickness		
	< 0.70	0.70~< 1.20	≥ 1.20	< 0.70	0.70~< 1.20	≥ 1.20
≤ 1200	10	8	7	5	4	3
> 1200~1400	12	10	8	6	5	4

按高级不平度供货时，仲裁情况下另需检验波浪度，波浪应符合以下规定：

- 当波浪长度不小于200mm时，波浪高度应小于波浪长度的1%。
- 当波浪长度小于200mm，波浪高度应不大于2mm。

When ordering is restricted flatness, it is necessary, but only in case of dispute, to verify the wave height:

- If the length of an edge wave is not less than 200mm, its maximum height does not exceed 1% of its length.
- If the length of an edge wave is less than 200mm, its maximum height does not exceed 2mm.

■ 力学性能标准规定值

Mechanical Properties Specified Value

牌号 Symbol	时效特性(拉伸应变痕) Aging Characteristics (stretcher strain)	屈服强度 Yield Strength MPa ≤	抗拉强度 Tensile Strength MPa ≥	断后伸长率(L ₀ =50mm, b=25mm) % 不小于 Elongation (L ₀ =50mm, b=25mm) % ≥			
				公称厚度 mm/Nominal Thickness			
				0.4~<0.6	0.6~<1.0	1.0~<1.6	≥ 1.6
SECC	—	—	270	34	36	37	38
SECD	自制造完成之日起3个月内使用不应出现拉伸应变痕 Products shall be free from stretcher strains marks within 3 months from manufactured date.	240	270	36	38	39	40
SECE	自制造完成之日起6个月内使用不应出现拉伸应变痕 Products shall be free from stretcher strains marks within 6 months from manufactured date.	220	270	38	40	41	42

注1 当屈服现象不明显时采用R_{P0.2}，否则采用R_{eL}。

注2 当厚度大于0.40mm且不大于0.60mm时，屈服强度的规定值允许增加20MPa；当厚度为0.40mm时，屈服强度的规定值允许增加40MPa。

Note 1: If the yield strength is not pronounced, the yield strength values apply to the 0.2%-proof strength(R_{P0.2})

Note 2: When 0.4mm<T<0.6mm, specified yield strength should be increased by 20MPa; When thickness is equal to 0.4mm, specified yield strength should be increased by 40 MPa.

如对厚度允许偏差、不平度、力学性能等有特殊要求，可协商供货。

If any special requirement on thickness tolerance, flatness and mechanical properties, etc, please mention it at the time of ordering.

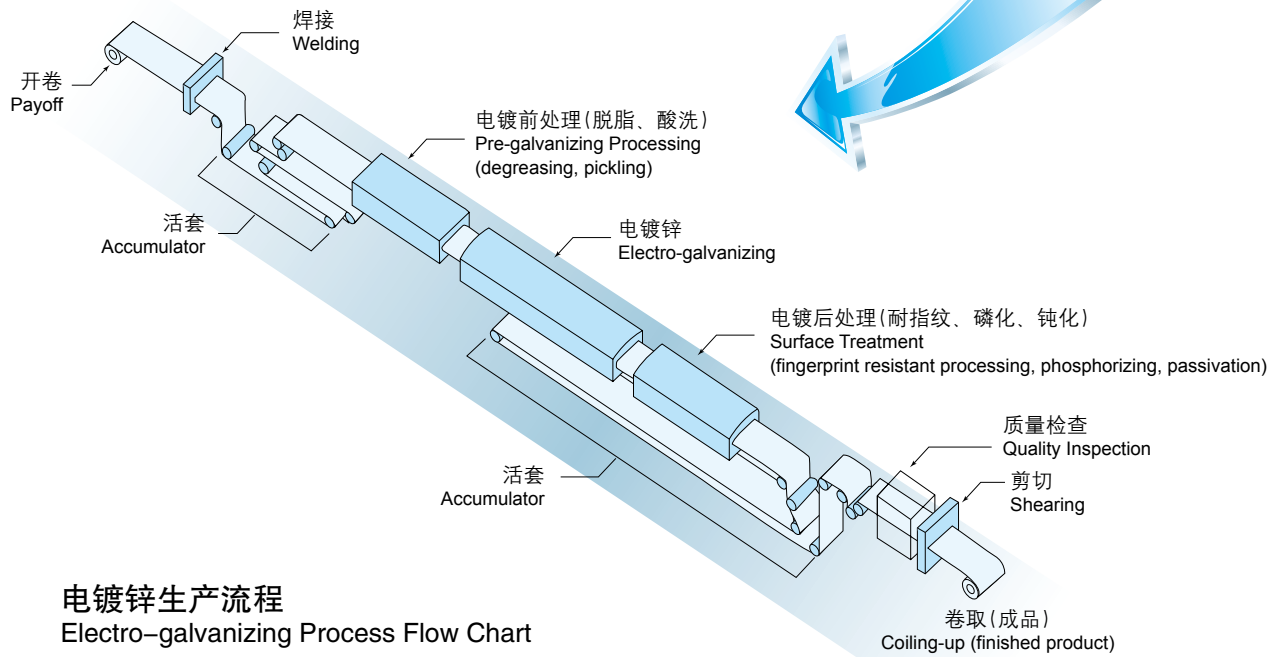
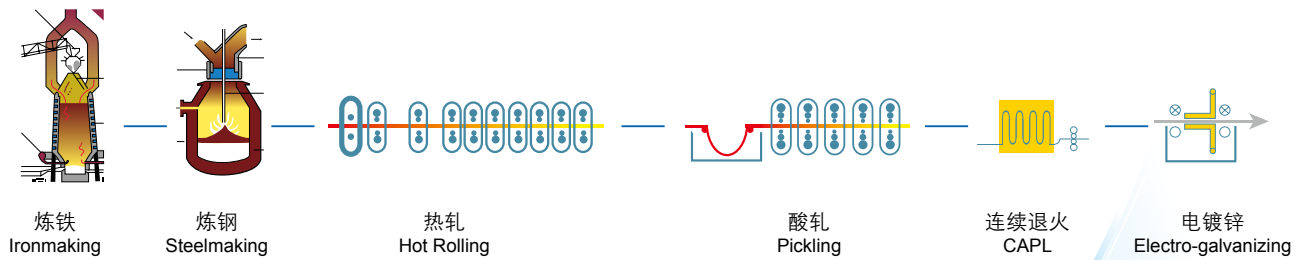

电镀锌生产流程
Electro-galvanizing Process Flow Chart

■ 耐腐蚀性

Corrosion Resistance

采用盐雾试验 (JIS Z 2371) , 以表面白锈率 (WR%) 表征, 分别评价平板和加工部位的耐腐蚀性。

Salt spray test (JIS Z 2371):

The corrosion resistance of flat surface section and formed section is evaluated by surface white rust ratio (WR%)

平板耐腐蚀性试验实例

Example of Corrosion Resistance of Flat Surface Section

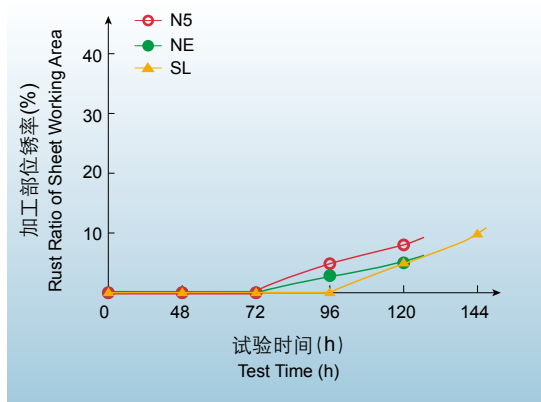

杯突7mm耐腐蚀性试验实例

Example of Corrosion Resistance of Formed Section (Erichsen 7mm Extruded Section)

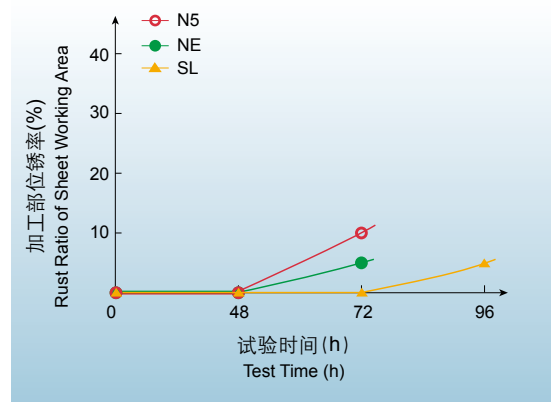

平板及杯突7mm盐雾照片

Photograph of Corrosion Resistance of Flat Surface Section and Erichsen 7mm Extruded Section

涂层类型	平板 / Flat Surface Section	杯突 / Erichsen 7mm Extruded Section
N5	SST 96h (平板 / Flat Surface Section)	SST 48h, SST 72h
NE	SST 120h (平板 / Flat Surface Section)	SST 48h, SST 72h
SL	SST 144h (平板 / Flat Surface Section)	SST 48h, SST 72h

■ 耐指纹性

Fingerprinting Resistant

表面涂层类型 Surface Coating Types	评价方法 Evaluation Method	色差 (ΔE^*) Chromatism (ΔE^*)
N5	擦拭前后钢板表面的色差值 (凡士林擦拭法) Chromatism Values of the Steel Sheet Surface before and after wiping with Vaseline	< 2.0
NE	浸泡前后钢板表面的色差值 (人工指纹液 (JIS K2246) 浸泡5秒钟) Chromatism Values of the Steel Sheet Surface before and after dipping-in with Artificial Fingerprinting Solution (JIS K2246) for 5 seconds.	< 1.0
SL	擦拭前后钢板表面的色差值 (凡士林擦拭法) Chromatism Values of the Steel Sheet Surface before and after wiping with Vaseline	< 2.0

产品表面性能示例

Example of Typical Properties

■ 导电性

按JIS C2550进行层间电阻试验

试验电压：0.5V

电流范围：0 ~ 1A

触头表面积：1cm² × 10触点

试验压力：2N/mm² ± 5%

Laminar Resistance Test (JIS C2550)

Test voltage: 0.5V

Current range: 0 ~ 1A

Contact surface area: 1cm² × 10 contact points

Test pressure: 2N/mm² ± 5%

层间电阻

Laminar Resistance

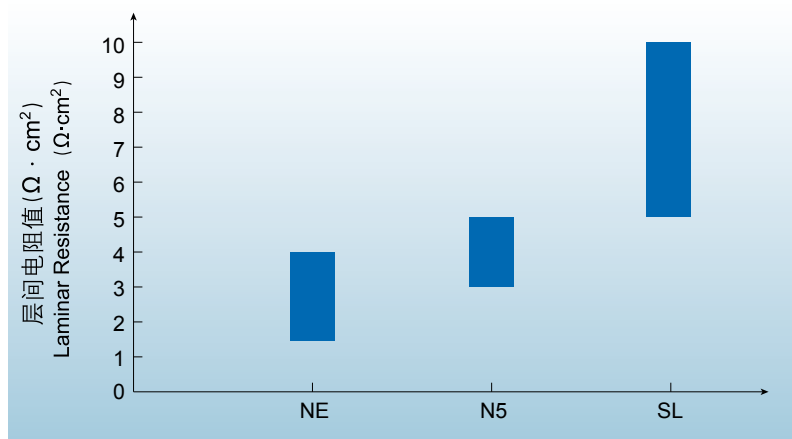

■ 表面电阻(4探针式)

LORESTA-EP低阻抗表面接触

电阻测定仪, ESP探针

评价

$$\text{导通率 (\%)} = \frac{\text{导通次数}^*}{20\text{次}} \times 100$$

*导通: 小于1mΩ

Lorsta (4 prove type)

Lorsta type

Assessment

$$\text{Conducting rate (\%)} = \frac{\text{conducting cycle}^*}{20\text{ cycles}} \times 100$$

*Conducting: Less than 1mΩ

表面电阻

Surface Resistance

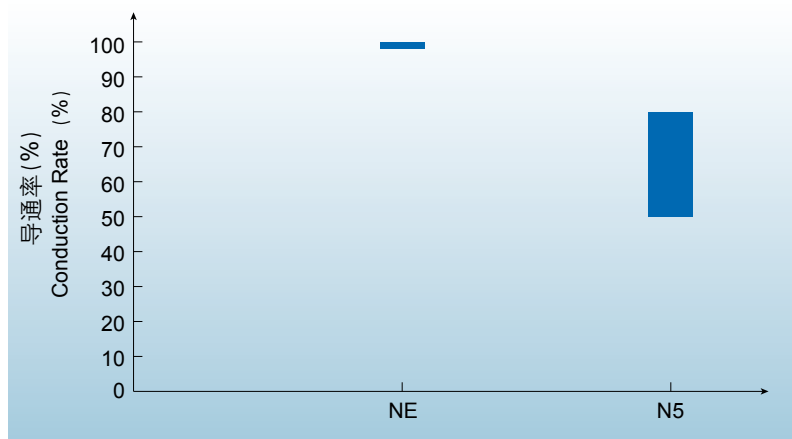

■ 润滑性

动摩擦系数

试验状态：不涂油

触头：ø10mm不锈钢球滑动

滑动速度：150mm/min

负荷：100g-f

■ Lubricity

Dynamic friction coefficient

Test status: No oil condition

Contact part: ø10mm sus ball

Moving speed: 150mm/min

Load: 100g-f

动摩擦系数

Dynamic Friction Coefficient

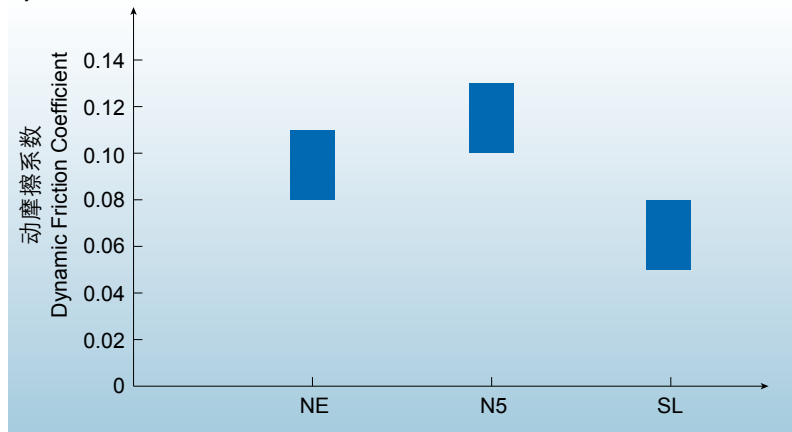

涂装性

Painting Adhesiveness

涂装条件

涂料种类 Paint types	膜厚 Coating Film Thickness	烘烤条件 Baking Condition	试验结果 Test Result		
			N5	NE	SL
三聚氰胺醇酸树脂涂料 (A04-9白色氨基烘漆, 上海振华造漆厂制造) Melamine alkyd resin paint (A04-9 white amino baking paint, made by Shanghai Chenhua Paint MFG Company)	20微米 20 micrometer	140°C × 40min	无剥离 No peeling	无剥离 No peeling	无剥离 No peeling
丝网印刷油墨(精工#1300EX油墨) Screen printing ink (Seiko #1300EX ink)	10微米 10 micrometer	120°C × 20min	无剥离 No peeling	无剥离 No peeling	无剥离 No peeling

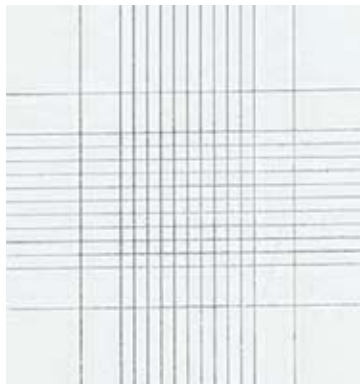

三聚氰胺醇酸树脂 (划格试验)
Melamine alkyd resin (Cross cut test)

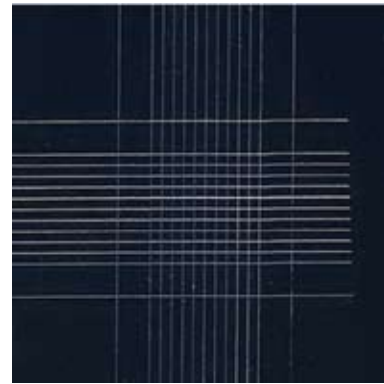

油墨 (划格试验)
Ink (Cross cut test)

耐溶剂性

Solvent Resistance

涂层类型 Coating Type	试验条件 Test Conditions	试验结果 Test Result
N5	M.E.K(丁酮)或者80%酒精擦拭20次 Wiping by M.E.K (butanone) or 80% alcohol for 20 times	≥ 3级 ≥ level 3
SL		
NE	常用有机溶剂浸泡168h Soaking of common organic solvent for 168h	5级 level 5

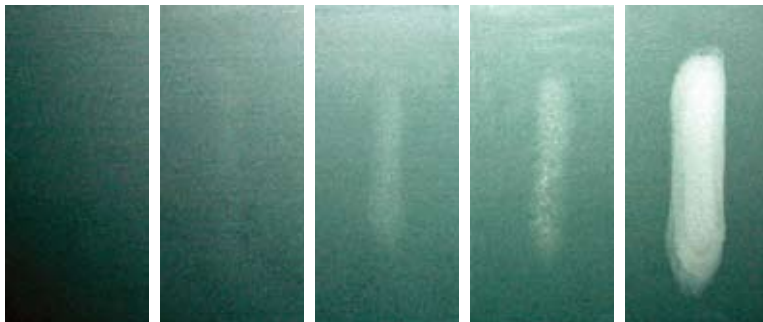

5级
level 5

4级
level 4

3级
level 3

2级
level 2

1级
level 1

等级说明:

5级: 表面无任何损伤;

4级: 正面观察表面无损伤, 侧光下皮膜轻微损伤;

3级: 正面可见皮膜轻度损伤;

2级: 皮膜损伤严重, 但未暴露基板;

1级: 皮膜完全脱落。

Level description

Level 5: no surface damage;

Level 4: no visible damage under front side observation, but minor film damage could be found from side light;

Level 3: visible light damage of the film on the front side;

Level 2: serious damage of the film but without exposing the base plate;

Level 1: Complete peeling of the film;

使用注意事项 Precaution in Use



【储存及运输】

- 保证产品在储存、运输及装卸过程中避免受潮，否则可能导致产品生锈。
- 建议选择加塑料袋的包装方式，以避免产品受潮。
- 高温、高湿、亚硫酸气体环境不利于产品的储存，不要长时间存放在此类环境中。
- 在储存及运输过程中，需防止发生钢卷的侧翻、滚动以及散包。

【加工及使用】

- 强碱清洗和超声波清洗会对表面涂层造成损伤，建议选用中低碱性的脱脂剂，尽量不使用超声波。
- 使用某些有机溶剂擦拭表面有可能会损伤表面涂层，建议试验后再使用。
- 如需磷化处理，磷化液温度和游离酸浓度不易过高，否则会对表面涂层造成损伤。
- 如表面吸附油污或粉尘可能影响涂装性能。

【时效】

- 由于时效的影响，钢板及钢带的力学性能和加工性能会随着时间的延长而变差，如屈服强度和抗拉强度上升、断后伸长率下降以及加工性能降低等，建议尽早使用。

【其他】

- 开卷操作应在确保安全的场所进行，防止钢卷外圈及捆带弹出，避免对周围的人员、物品造成伤害。
- 在剪断捆带前，请将钢卷最外圈端部置于钢卷的下方。

Storage and Transportation

- Products must be kept from moisture during storage, transportation and loading/unloading, otherwise they may get rusted.
- It is recommended that plastic bag could be added in the package to avoid moisturized products.
- It is to the disadvantage of the product storage to have an environment of high temperature, high humidity and sulfur-dioxide gas. Products should not be placed in such a kind of environment for long time.
- During storage and transportation, side roll over, rolling and loose packaging of steel coils must be prevented.

Processing and Usage

- Strong alkaline type cleaning and ultrasonic cleaning will cause damage to the surface coating, therefore, it is recommended to use weak alkaline type cleaning and try not to use ultrasonic.
- Surface wiping by some organic solvent may result in damage of surface coating and it is recommended to carry out trial test before using.
- If phosphating is needed, phosphating solution temperature and free acid concentration should not be too high; otherwise the surface coating will get damaged.
- Adhesion of oil stain or fine dust to the surface may influence the painting characteristics.

Aging

- Due to effects of aging, mechanical properties and processing properties of the steel plates and steel strip shall deteriorate with time passing. For example, yield strength and tensile strength value will rise, elongation value will decrease and processing properties will drop, etc. It is suggested to use the material as early as possible.

Others

- Pay off shall be done in an ensured-safe area and spring-out of steel coil or its strapping shall be prevented from causing injury or damage to people and goods in the vicinity.
- Before cutting the strapping, the outer end of the steel coil shall be put right under the coil.

订货需提供下列信息

- a) 产品名称 (钢板或钢带)
- b) 产品标准、牌号和表面处理类型
- c) 尺寸及其精度要求
- d) 不平度精度要求
- e) 镀层重量
- f) 表面质量等级
- g) 重量
- h) 包装方式
- i) 其他特殊要求可在订货时提出

订货标准示例

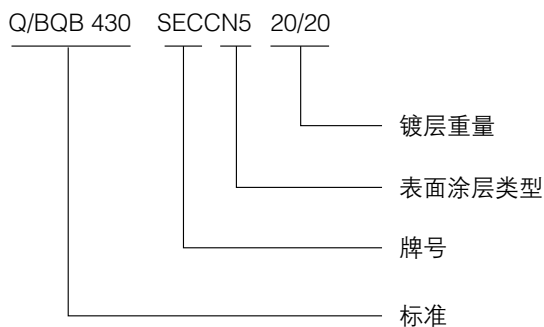

Information to Be Supplied at The Time of Ordering

- a) product type (sheet or strip)
- b) the number of standard, symbol and surface treatment type
- c) nominal dimension and tolerances
- d) flatness tolerance
- e) coating mass
- f) surface quality
- g) weight
- h) packaging type
- i) others

Indication of Specifications

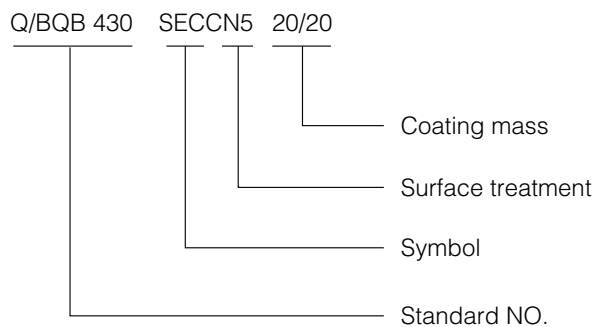

包装、标志及检验文件

Packaging, Marking and Inspection Certificate

标签

钢板及钢卷的外包装上至少粘贴二张标签，标签的内容可包括商标、公司名称及制造厂、品名、标准、规格、捆包号、用户合同号、制造日期、计重方式、净重、毛重、收货单位、防护标志等。

标签示例

Tag example

Label

2 tables at least must be affixed on the external package of steel sheet or coils. The following contents are included: the trademark, company and manufacture name, product type, standard number, dimension, pack number, contact number, manufacturing date, weight calculation method, net weight, gross weight, purchaser and markings additionally.

		宝山钢铁股份有限公司 BAOSHAN IRON & STEEL CORPORATION LTD.		总部 CORE BASE		怡湿 KEEP DRY	
品名 PRODUCT					日期 DATE		
标准 SPECIFICATION					计重方式 WEIGHT ARKER		
规格 SIZE			净重 kg NET WEIGHT			毛重 kg GROSS WEIGHT	
捆包号 COIL/PACK NO.			颜色 COLOR				
用户合同号 CONTRACT NO.			张数 SHEETS	炉号 HEAT NO.	镀层重量 g/m ² COATING WEIGHT		
到站港 DESTINATION							
收货单位 PURCHASER							

库号
WAREHOUSE NUMBER

批号
Lot number

包装、标志及检验文件

Packaging, Marking and Inspection Certificate

包装

Packing

包装方式由用户选择；
如用户未指定包装方式，则由我们确定合适的包装方式。

The packaging type should be selected by purchaser. If there is absent of any packaging selection, the packageing type shall be left to the discretion of the manufacturer.

钢卷包装示例

Example of Packaging for Steel Coil

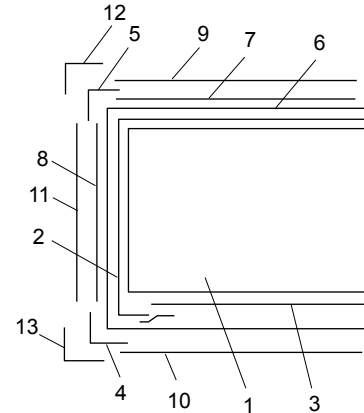
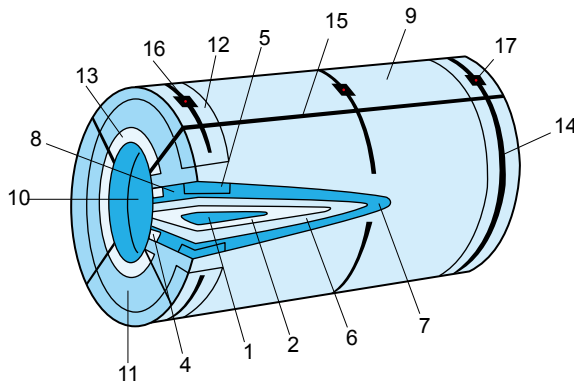

- | | | |
|--------------|----------|----------|
| 1. 钢卷 | 2. 外周防锈纸 | 3. 内芯防锈纸 |
| 4. 纸内护角 | 5. 纸外护角 | 6. 塑料套 |
| 7. 外周瓦楞纸或纤维板 | 8. 圆护瓦楞纸 | |
| 9. 外周包板 | 10. 内周护板 | 11. 铁圆护板 |
| 12. 铁外护角 | 13. 铁内护角 | 14. 周向捆带 |
| 15. 径向捆带 | 16. 锁扣垫片 | 17. 锁扣 |

- | | |
|--|-------------------------------------|
| 1. Coil | 2. Outside anti-tramish paper |
| 4. Insider paper corner protection | 6. Plastic film cover |
| 8. Lateral-protection corrugated paper | 10. Inner side circular cover plate |
| 12. Outside steel corner protection | 14. Circumference strap |
| 16. Seal protector | |

- | |
|------------------------------------|
| 3. Inside anti-tramish paper. |
| 5. Outside paper corner protection |
| 7. Circular protection paper |
| 9. Outside circular cover plate |
| 11. Lateral-protection cover plate |
| 13. Inside steel corer protection |
| 15. Radial strap |
| 17. Seal |

钢板包装示例

Example of Packaging for Steel Sheet

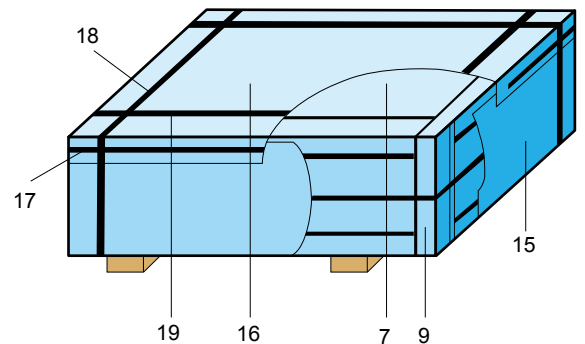
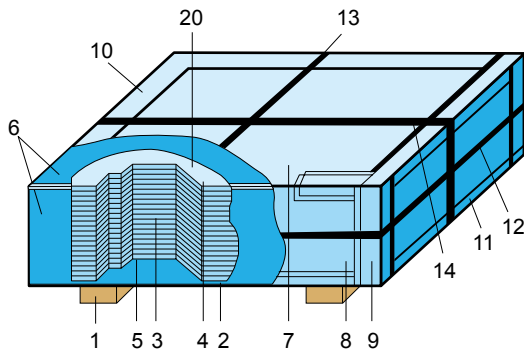

- | | | |
|-------------|-------------|-------------|
| 1. 木台 | 2. 底板 | 3. 钢板 |
| 4. 上盖板 | 5. 底部瓦楞纸 | 6. 防锈纸 |
| 7. 上部瓦楞纸 | 8. 端面瓦楞纸 | 9. 边部护角 |
| 10. 上部护角 | 11. 下部护角 | 12. 周向捆带(内) |
| 13. 横向捆带(内) | 14. 纵向捆带(内) | 15. 围板 |
| 16. 铁盒 | 17. 周向捆带(外) | 18. 横向捆带(外) |
| 19. 纵向捆带(外) | 20. 塑料套 | |

- | | |
|--------------------------------|-------------------------------------|
| 1. Wooden deck platform | 4. Top cover |
| 7. Top crrugated paper | 9. Edge corner protection |
| 11. Bottom corner protection | 13. Crosswise strap (inner) |
| 15. Lateral protection plate | 17. Circumferential strap (outside) |
| 19. Lengthwise strap (outside) | |

- | | |
|-------------------------------|-----------------------------------|
| 2. Bottom cover | 3. Sheet |
| 6. Anti-tarnish paper | 8. End fluting paper |
| 10. Top corner protection | 12. Circumferential strap (inner) |
| 14. Lengthwise strap (inner) | 16. Box cover |
| 18. Crosswise strap (outside) | |
| 20. Plastic cover | |

■ 检验文件 Inspection Document

- 通常情况下，由我们根据规定的检验和试验要求进行检验和试验，并出具检验文件。经供需双方协商，并在合同中注明，也可提供其它类型的检验文件。
- 检验文件内容包括：商标、公司名称及制造厂、产品名称、收货单位、订货单位、产品标准、钢卷号或捆包号、用户合同号、炉号、标准中规定的各项试验结果、检验文件签发日期、质量负责人签章等。
- In normal cases, we shall carry out inspection and tests based on stipulated requirements and issue an inspection report. Through bilateral negotiations between Buyer and Seller and by marking in the contract, inspection document of other types could also be submitted.
- The content of inspection document include: trademark, company name and manufacturer, product name, purchaser, customer, standard number, package number, order number, heat number, test result specified in relevant standard, inspection certificate issued date, signature of manager of manufacturing management dept., etc.

检验文件（产品质量证明书）示例
Example of Inspection Certificate (Product Quality Certificate)

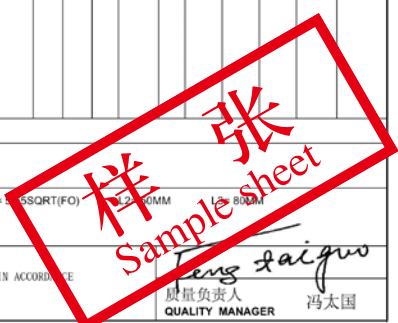
 宝山钢铁股份有限公司 BAOSHAN IRON & STEEL CO.,LTD.		产品质量证明书 INSPECTION CERTIFICATE		上海市宝山区富锦路885号 邮编 201900 No.885 Fujin ROAD, BAOSHAN DISTRICT 201900 SHANGHAI, P. R. CHINA TEL (021)26649104 FAX (021)26649104																												
制造厂：总部 Manufacturer: CORE BASE																																
订货单位 CUSTOMER	*****	产品名称 PRODUCT	电镀锌钢带																													
收货单位 PURCHASER	*****	代号 CUSTOMER'S NO.	*****	证书号 CERTIFICATE NO.	*****																											
标准 SPECIFICATION	Q/BQB 430 SECCN5 20/20 FD	客户订单编号 CUSTOMER ORDER NO.																														
	PT. B-PW. A-PF. B	签发日期 DATE OF ISSUE	****/**/**																													
		许可证号 LICENSE NO.	合同号 MILL'S NO.	*****																												
序号 NO.	钢卷/捆包号 COIL/PACK NO.	件数 QTY	炉号 HEAT NO.	规格及重量 MATERIAL DESCRIPTION		化学成分 CHEMICAL COMPOSITION % (熔体分析 HEAT ANALYSIS)						拉伸试验 TENSILE TEST (G.L= L2)			*01 号 曲	硬度 HARD NESS	*02 杯 突	镀层重量 COATING MASS			服务热线 800-820-8590 021-26648888											
				厚度 THICK	宽度 WIDTH	长度 LENGTH	张数 SHEETS	重量 MASS (kg)	C	Mn	P	S	Al							屈服 Y.S.		抗拉 T.S.	伸长 EL	值	值	值	值	两面 BOTH	上面 TOP	下面 BOT		
1	*****	1	*****	1.00	1050	COIL		11640	4	19	10	8	44							305		365	44					OK	56	45.0	23.0	22.0
2	*****	1	*****	1.00	1050	COIL		11460	4	19	10	8	44							305		365	44					OK	56	45.0	23.0	22.0
合计 Total		2		23100																												
备注 REMARKS																																
注释 NOTES		Y.S.= YIELD STRENGTH T.S= TENSILE STRENGTH EL= ELONGATION G.L= GAUGE LENGTH L1= 55QRT(FO) L2= 20MM L3= 80MM *01:COATING BEND TEST *02:ERICHSEN																														
会验者 SURVEYOR TO		本产品已按上述要求进行制造和检验，其结果符合要求，特此证明。 WE HEREBY CERTIFY THAT MATERIAL DESCRIBED HEREIN HAS MANUFACTURED AND TESTED WITH SATISFACTORY RESULTS IN ACCORDANCE WITH THE REQUIREMENTS OF THE ABOVE MATERIAL SPECIFICATION.																														
		 质量负责人 冯太国 QUALITY MANAGER 冯太国																														

Page 1 of 1

宝山钢铁股份有限公司
http://www.baosteel.com

BAOSHAN IRON & STEEL CO., LTD.
http://www.baosteel.com

薄板销售部
Steel Sheet Sales Department
地址(Add): 上海宝山同济路1800号
邮编(P.C.): 201900
电话(TEL): 021-26645186
传真(FAX): 021-26645005

产品发展部
Product Development Department
Add: No.1800 Tongji Road, Baoshan, Shanghai
邮编(P.C.): 201900
电话(TEL): 021-26649634
传真(FAX): 021-26645295

宝钢服务热线
Baosteel Service Hot-line
800-820-8590
021-26648888

宝钢在线
http://www.baosteel.net.cn

国内贸易公司

上海宝钢钢材贸易有限公司 电话: 021-50509696 传真: 021-68404618	广州宝钢南方贸易有限公司 电话: 020-32219999 传真: 020-32219555	天津宝钢北方贸易有限公司 电话: 022-84905800 传真: 022-84905806	成都宝钢西部贸易有限公司 电话: 028-85335388 传真: 028-85335680
武汉宝钢华中贸易有限公司 电话: 027-84298800 传真: 027-84298224	上海宝钢商贸有限公司 电话: 021-56121212 传真: 021-56126584	上海宝钢浦东国际贸易有限公司 电话: 021-36014655 传真: 021-51266522 51266533	上海宝钢宝山钢材贸易有限公司 电话: 021-36014688 传真: 021-51266500
长春宝钢钢材贸易有限公司 电话: 0431-85889320 传真: 0431-85889317	沈阳宝钢钢材配送有限公司 电话: 024-62220699 传真: 024-88210198		

亚澳地区 Asia and Australia

宝和通商株式会社 HOWA TRADING CO., LTD. TEL: 0081-3-3237-9121 FAX: 0081-3-3237-9123	宝和通商首尔事务所 HOWA TRADING CO., LTD., SEOUL OFFICE TEL: 0082-2-5080893 FAX: 0082-2-5080891	宝钢澳大利亚贸易有限公司 BAO AUSTRALIA PTY LTD. TEL: 0061-8-94810535 FAX: 0061-8-94810536
宝钢新加坡贸易有限公司 BAOSTEEL SINGAPORE PTE LTD. TEL: 0065-63336818 FAX: 0065-63336819	越南代表处 VIETNAM REPRESENTATIVE OFFICE TEL: 0084-8-39100126 FAX: 0084-8-39100124	泰国代表处 THAILAND REPRESENTATIVE OFFICE TEL: 0066-2-6543008 FAX: 0066-2-6543010

欧非地区 Europe and Africa

宝钢欧洲有限公司 BAOSTEEL TRADING EUROPE GMBH TEL: 0049-40-4199410 FAX: 0049-40-41994120	宝钢西班牙有限公司 BAOSTEEL ESPAÑA, S.L. TEL: 0034-93-4119325 FAX: 0034-93-4119330
宝钢中东代表处 BAOSTEEL MIDDLE EAST REPRESENTATIVE OFFICE TEL: 00971-4-8810788 FAX: 00971-4-8810789	宝钢意大利钢材集散中心有限公司 BAOSTEEL ITALIA DISTRIBUTION CENTER SPA TEL: 0039-010-530881 FAX: 0039-010-5308895

美洲地区 America

宝钢美洲贸易有限公司 BAOSTEEL AMERICA INC. TEL: 001-201-3073355 FAX: 001-201-3073358	底特律代表处 DETROIT REPRESENTATIVE OFFICE TEL: 001-248-2089918 FAX: 001-248-2080999	休斯顿代表处 HOUSTON REPRESENTATIVE OFFICE TEL: 001-281-4847333 FAX: 001-281-4842655
洛杉矶代表处 LOS ANGELES REPRESENTATIVE OFFICE TEL: 001-949-7526789 FAX: 001-949-7521234	里约代表处 BAOSTEEL DO BRAZIL LTDA. TEL: 0055-21-25311363 FAX: 0055-21-25310298	

